



Xorel Artform[®]
Acoustical Panels

Carnegie Xorel[®]

IN GOOD COMPANY

Creative curiosity is inherent to Carnegie, as is our commitment to quality, performance, and sustainability. As a design company focused on driving innovation, we are dedicated to the development of high performing, environmentally responsible textiles for building interiors. That steadfast commitment has led to breakthrough fabric introductions, such as Xorel and Xorel Biobased, that are unrivaled in form, function, and environmental performance.

Based in New York City, the Carnegie Creative Studio is dedicated to exploration, research, and material innovation. Our talented and diverse team includes textile designers, weavers, painters, and graphic designers committed to examining new technologies. This commitment allows us to create bespoke materials for our clients—an ability unsurpassed in the industry. We invite you to visit when you are in the area and discover the possibilities of partnering with Carnegie.



Carnegie is a
Certified B Corporation

B Corp certification is a rigorous third party assessment performed by the non profit organization B Lab. B Corporations are a new kind of company that uses the power of business to solve social and environmental problems.

bccorporation.net



Carnegie is a
Member of Be Original

Be Original Americas is committed to informing, educating and influencing manufacturers, design professionals and individuals on the economic, ethical, and environmental value of authentic design while preserving and investing in its future.

beoriginalamericas.com



Carnegie is a
PVC Free Company

Carnegie was the first and remains the only dedicated PVC Free company in our industry. Our mission is to work tirelessly to replace vinyl products with more environmentally intelligent materials.

Xorel Artform[®]

Xorel Artform is a versatile acoustical panel system that combines the beauty and performance of Xorel textiles with proven sound absorbing capabilities to transform interior wall spaces in form and function without disruption.

Xorel continues to set the industry standard for high-performing interior textiles by providing a design solution that's both beautiful and versatile. Available in more than 300 colors, patterns and textures, Xorel provides boundless opportunity for designing unique environments in hotels, healthcare, offices, schools, and beyond.

A woven polyethylene with strength at its core, Xorel achieves high durability and ease of maintenance without added coatings or finishes. Cradle-to-Cradle™ Certified, lab tested, and proven for over 35 years with installations around the globe, Xorel is the safest, most environmentally responsible textile on the market.

Introduced in 2013, Biobased Xorel is sourced from rapidly renewable sugarcane, and is the world's first and only biobased high performance interior textile. It is Cradle-to-Cradle Gold Certified.





Carmegje Xorel

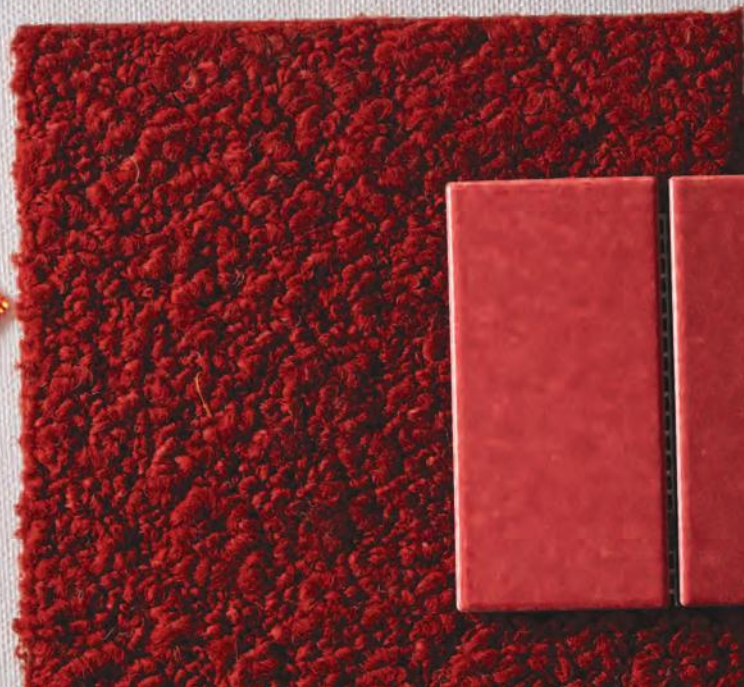

**Textiles
Take Shape**





Artful Possibilities

With a wide array of panel shapes, sizes, and three-dimensional options available in over 300 Xorel textile patterns, textures and colors, design opportunities with Artform are unlimited.

Fully customized and signature designs are achievable with standard product, without ever replicating the same look twice.

Added Dimension

Three-dimensional panels, available in four shapes, can be used on their own or in concert with other Xorel Artform panels to add an enhanced sculptural element to any installation.

Dimension and structural variety also can be achieved by mixing panels of different substrates within the same composition.

A Sound Decision

Addressing acoustics in open areas remains a constant challenge when designing interior spaces. Xorel Artform finished panels provide an effective solution for sound absorption and echo reduction while granting creative design opportunities limited only by the imagination.



Square 3D in size Small, Large
Plank in size Small, Large
Fabric on panels: Meteor 6427 colors 754, 722, and 725
Fabric on wall: Meteor 6427 color 762



Diamond in size Small, Medium, Large
Diamond 3D in size Small, Medium, Large
Fabrics on panels: Meteor 6427 colors 719, and 713;
Flux 6557 color 92; Twine 6217 colors 30, and 33;
and Pipeline 6207 color 61
Fabric on walls: Meteor 6427 colors 751, and 713





Hex in size Small
Hex 3D in size Small
Fabric on panels: Strie 6423 color 813;
Meteor 6427 colors 769, and 770







Waveline in size Small
Fabric on Panels: Meteor 6427 colors 722, 721, and 705;
Strie 6423 color 811
Furniture by HighTower



Plank in size Small, Large
Fabric on Panels: Meteor 6427 colors 716, 759, and 752;
and Brigitte Couture 6289 color 830

Versatility in application is easily achieved because Xorel Artform is uninhibited by clips or track systems.
This creates opportunity for free form layouts that can extend on to ceilings.



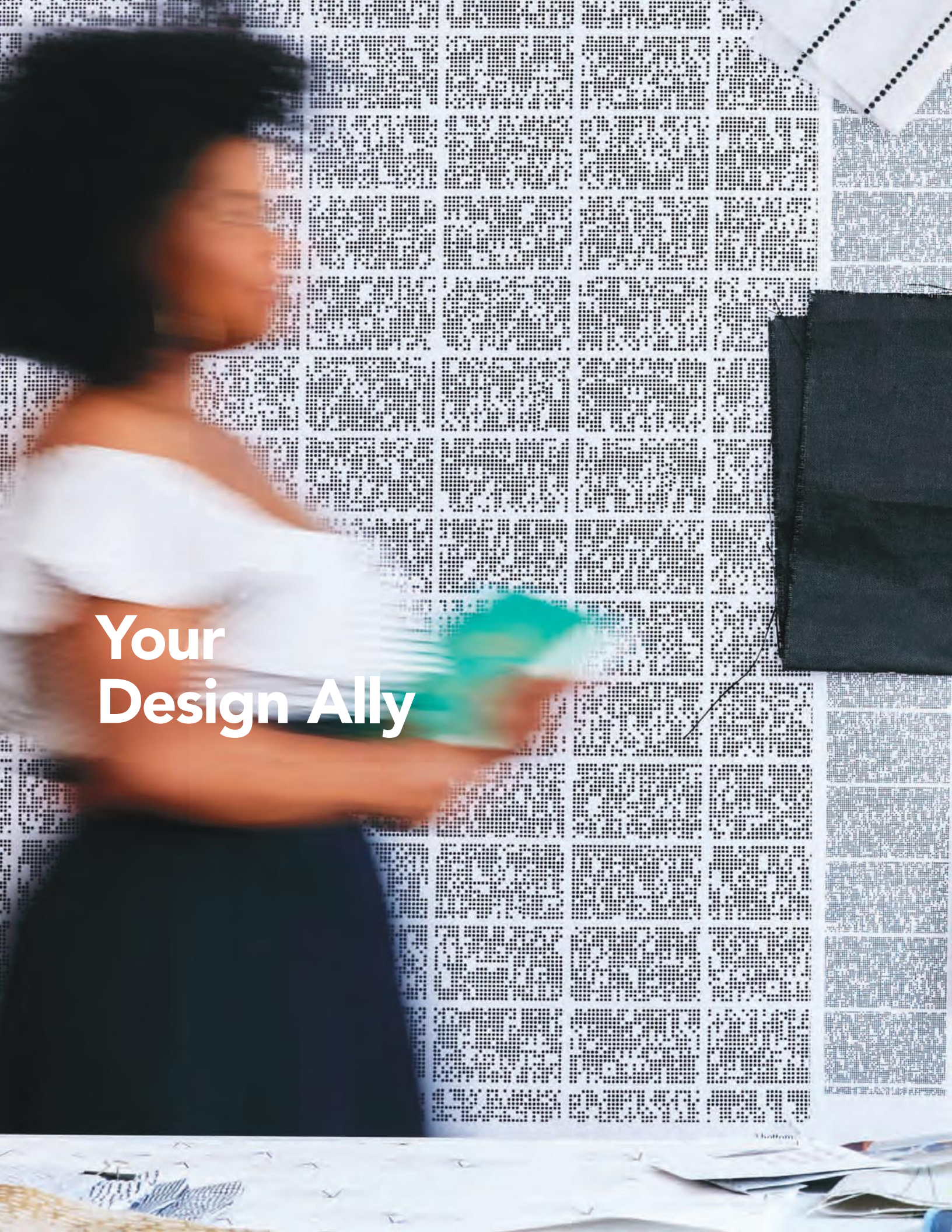

Your Design Ally

© 2018 [unreadable]

© [unreadable]





Creative Support

When time is of the essence and creativity can't be compromised, lean on us. Offered as a complimentary service, the Xorel Artform Design Ally team can generate prompt design layouts and make pattern/color suggestions based on your design narrative.

No matter the environment—from hospitality to healthcare, from offices to educational spaces and beyond—Design Ally can supply you with unique shape configurations inspired by your color palette and design vision.

Renderings and budget projections also are provided to support your specific project requirements.

Contact a Carnegie Salesperson, email xorelartformdesign@carnegiefabrics.com or visit xorelartform.com/designally.



Design Ally Process



01. Design Engagement—What are the wall dimensions? Design inspiration? Preference on Artform shapes and sizes? Budget parameters?

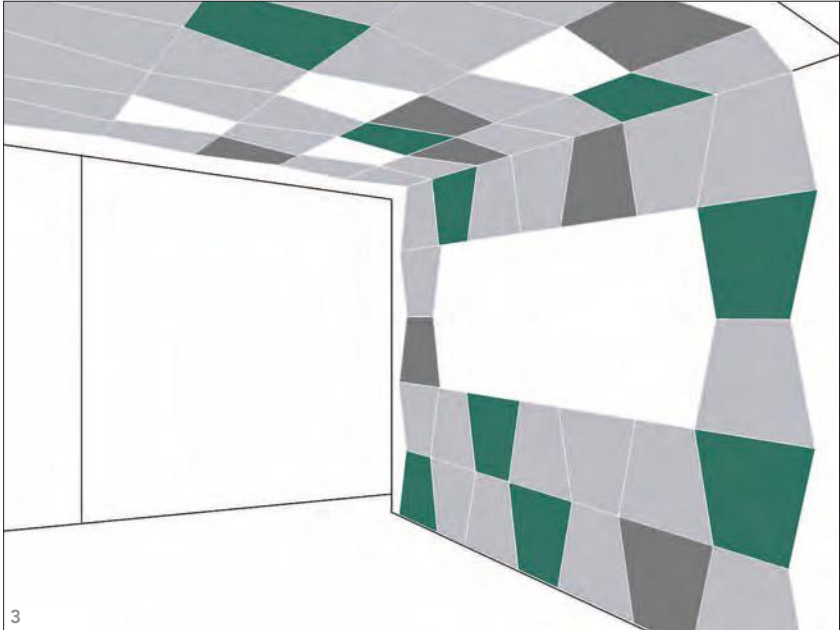
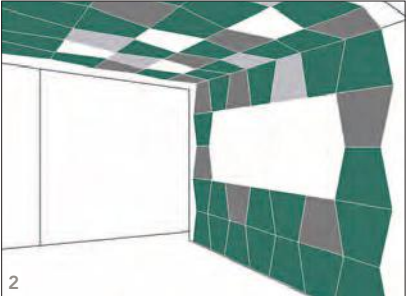
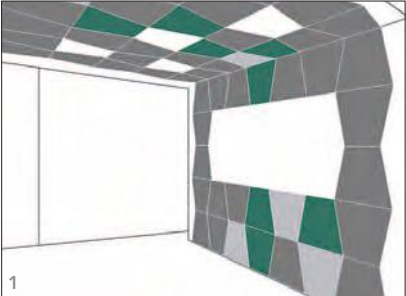

02. Design Ally Creative Concepts—Renderings are shared, ensuring design concepts achieve your vision.



Meteor 6427 738

2 Boxes / 10 Panels



Meteor 6427 766

2 Boxes / 8 Panels



Strie 6423 817

7 Boxes / 37 Panels

Project No.	AF043
Project Name	Meeting Room 4F
Shape	Waveline
Total Panels	55
Total Boxes	11

03. Project Order—Detailed product order specifications are provided for easy ordering.



04. Installation—The Design Ally team can direct you to our Preferred Installer Network to achieve superior installation results.



Varying the colors and patterns of Xorel woven textiles allows a flexibility of expression. By simply rotating panels, design connection points are altered—changing the highlights and shadows of the shapes to create new composition possibilities.





Waveline in size Large
Waveline 3D in size Large
Fabric on Panels: Meteor 6427 colors 751, 769, and 768;
Spire 6269 color 17; Deco Embroider 6265 color 817;
and Dash 6603 color 37

Details Matter





Xorel Artform's precision fabrication ensures that the completed installation matches the highest quality level of other architectural finishes on your project.

All Xorel Artform panels are crafted with beveled edges and clean, contoured corners for superior fit and finish, especially beneficial for large wall applications. Developed with proprietary techniques to ensure laser precision accuracy in fabrication, Artform is the only acoustical panel designed specifically for the use of Xorel textiles.

When details matter, Xorel Artform delivers. Whether the goal is addressing acoustics, providing functional tackable surfaces, or making a high impact design statement, Xorel Artform excels wherever beauty and utility are essential.

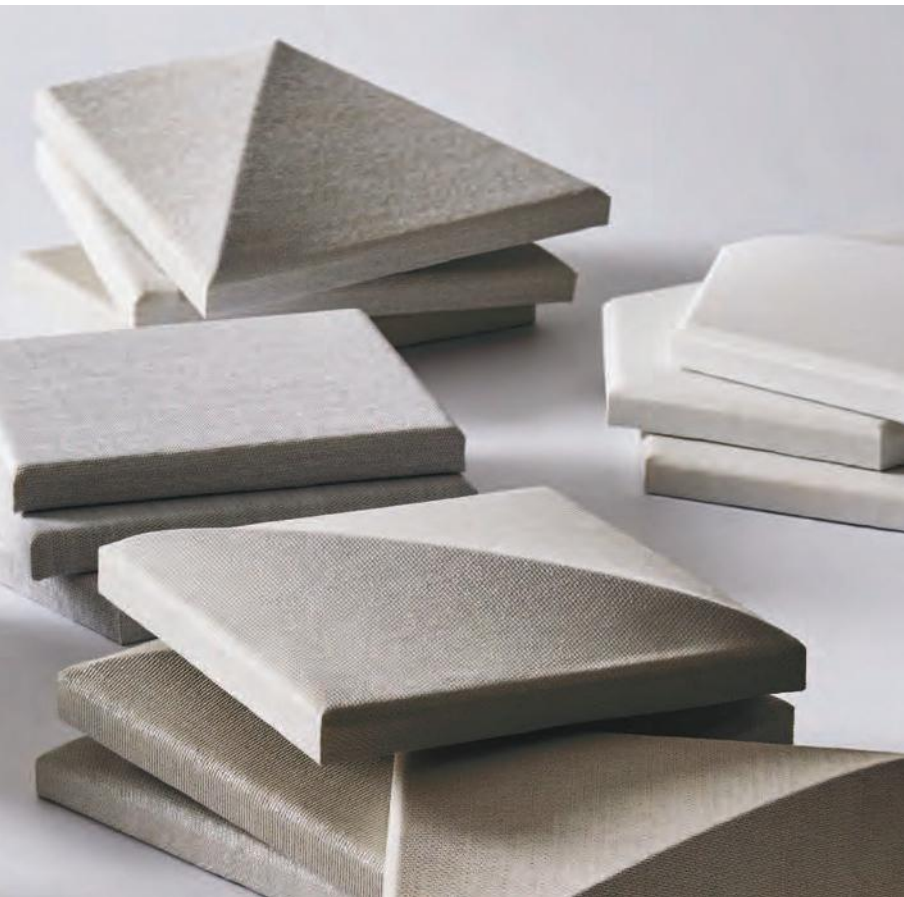



For additional functionality, Xorel Artform is available with a Mi-Core substrate option which provides moderate acoustical properties with a tackable surface.



Artform Shapes

Hex

Small



Medium

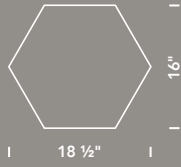

Large

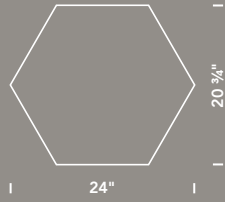

Hex 3D

Small



Medium

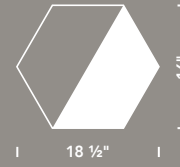

Large

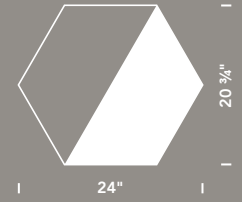

Waveline

Small

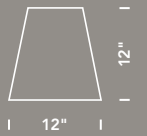

Medium

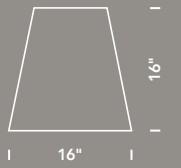

Large

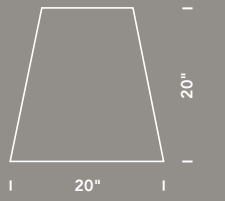

Waveline 3D

Small



Medium



Large

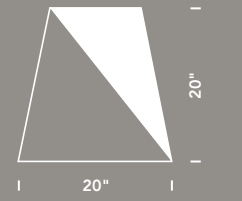

Diamond

Small



Medium



Large

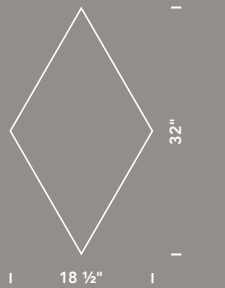

Diamond 3D

Small



Medium



Large

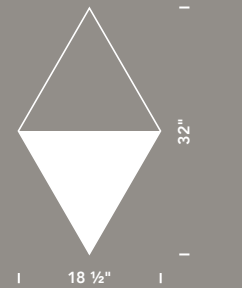

Square

Small



Large

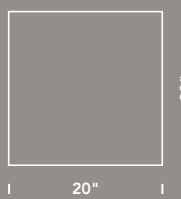

Square 3D

Small

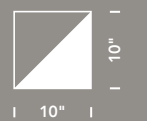

Large

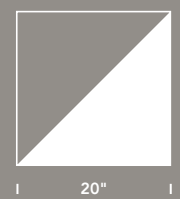

Box Sets

Xorel Artform is priced and sold in box sets of the same shape, size, substrate, fabric, and color. Complete box sets include 6 prefabricated panels of the standard shapes; 4 panels per box for the 3D shapes. Each box arrives to the job site securely packed and includes all installation and adhesive materials. Minimum order is 1 box.

Dimensional Orientation

Box sets of Hex, Waveline, and Square 3D panels include “handed” shapes which feature the dimensional element oriented towards either right or left. This attention to detail ensures that the specified Xorel fabric weave is wrapped along the panel in the same direction so that fit and finish are not compromised when changing panel orientation. Two of each handed shape are included in each box set.



3D Shapes Box Set

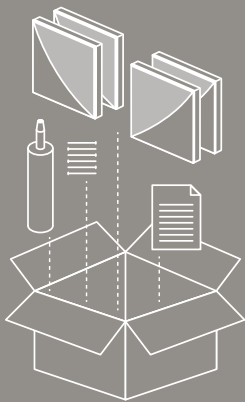

Standard Shapes Box Set

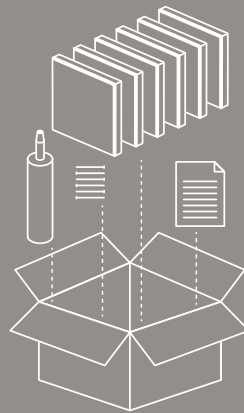

Substrate Options and Acoustical Performance

Quiet-Core™

This acoustical substrate is sound absorbing, formaldehyde-free and manufactured with 20% post-consumer recovered materials. It is available in a 1" thickness and used for all 3D shapes. It meets ASTM E84 Class A / Class 1.

Acoustical Performance

250Hz	.32
500Hz	.71
1000Hz	.98
2000Hz	1.10
4000Hz	.98
NRC	.70

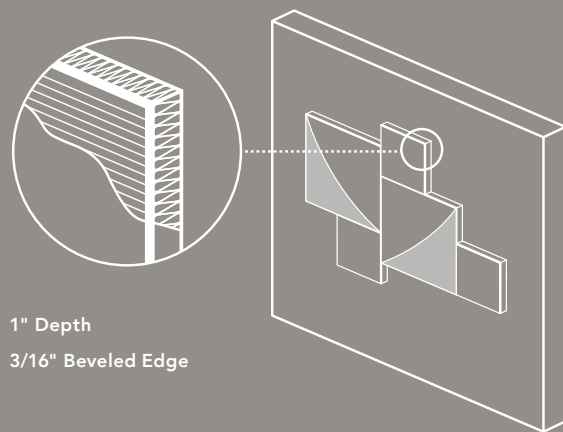

Mi-Core™

This tackable substrate offers moderate acoustical properties. Mi-Core™ is constructed with inorganic minerals and fibers making it resistant to moisture and warping. Mi-Core is a dense material recommended for high traffic areas. It is available in 1/2" & 3/4" thickness. It meets ASTM E84 Class A / Class 1.

Acoustical Performance

250Hz	.18
500Hz	.31
1000Hz	.36
2000Hz	.41
4000Hz	.46
NRC	.30

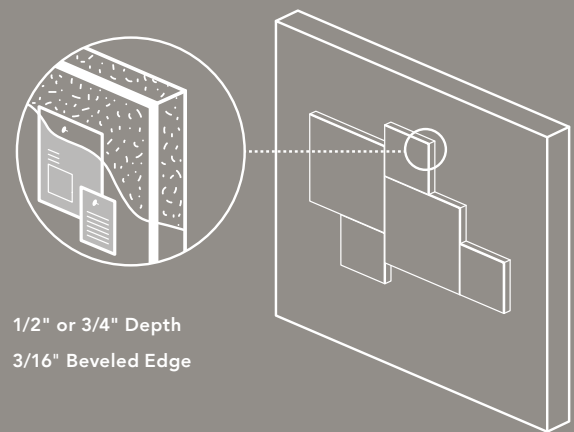

Install with Ease

Fast and easy to install with little disruption or major clean up, Xorel Artform is the optimal solution to address post-occupancy acoustical issues. Panels are lightweight and install simply with a quick-grab adhesive or Velcro® fasteners, eliminating the high labor costs associated with rail and hardware systems.

To ensure complete customer satisfaction and achieve superior installation results, a Preferred Installer Network of vetted and trained professionals expert in the capabilities, ordering and installation practice of Xorel Artform is available as an added service.





Why Xorel Artform

Leverages the high performance of Xorel textiles

- Durable and colorfast
- Antibacterial
- Easy to clean / bleach cleanable
- Free of chemical finishes
- 3rd Party Certified for sustainability
- Lab tested
- Over 300 colors, patterns and textures

Varying shapes and sizes to create limitless design possibilities

Acoustical and tackable properties

Simple installation with minimal labor costs

Design Ally - complimentary design support service

5-year Warranty

Fast Delivery: 2-6 week lead time

xorelartform.com

